

ITEM	REQ	DRAWING	DESCRIPTION
22	1	B-4481-7	Stop
21	4	B-4481-4	Stop yoke
20	4	A-4494-8A	Support bolt
19	4	A-4494-7A	Pivot pin
18	4	B-4481-6A	Roller housing
17	1	B-4481-5	Pivot bracket
16	8	A-4494-6	Bearing pin
15	16	A-4494-5	Bushing
14	8	A-4494-4	Support roller
13	1	A-4494-1	Link support
12	1	B-4481-2A	Link

ITEM	REQ	DRAWING	DESCRIPTION
11	1	B-4481-1	Stop housing
10	2	A-4286-6A	Cyl pin
9	2	A-4286-5A	Cyl pin
8	4	B-4047-2A	Pillow block
7	2	A-4286-4A	Pivot pin
6	1	E-4012-18D	Pivot base
5	6	A-4286-3	Gusset
4	1	E-4012-17E	Base
3	3	A-4286-2	Guide tube
2	3	B-4047-2	Stop tube
1	1	E-4012-21A	Table top

NOTE: due to machining tolerances install 7/8-9 foundation bolts in 1 1/2 sway pipe level table before grouting

ITEM	DESCRIPTION	PART NO.
	SAWING SYSTEMS INC. P.O. Box 3754 Knoxville TN 37927-3754 (865) 525-0600 (800) 489-0601 Telefax (865) 525-2320	
TITLING TABLE		
ASSEMBLY DWG		
DRAWN BY- M.Finkel		DATE- May 12 98
CHECKED BY-		SCALE- 1:8
MATERIAL-	REQ'D-	DRAWING NO.
LTR.	REVISION	DATE FOR-

tiltable/tiltab5

E-4021-8D

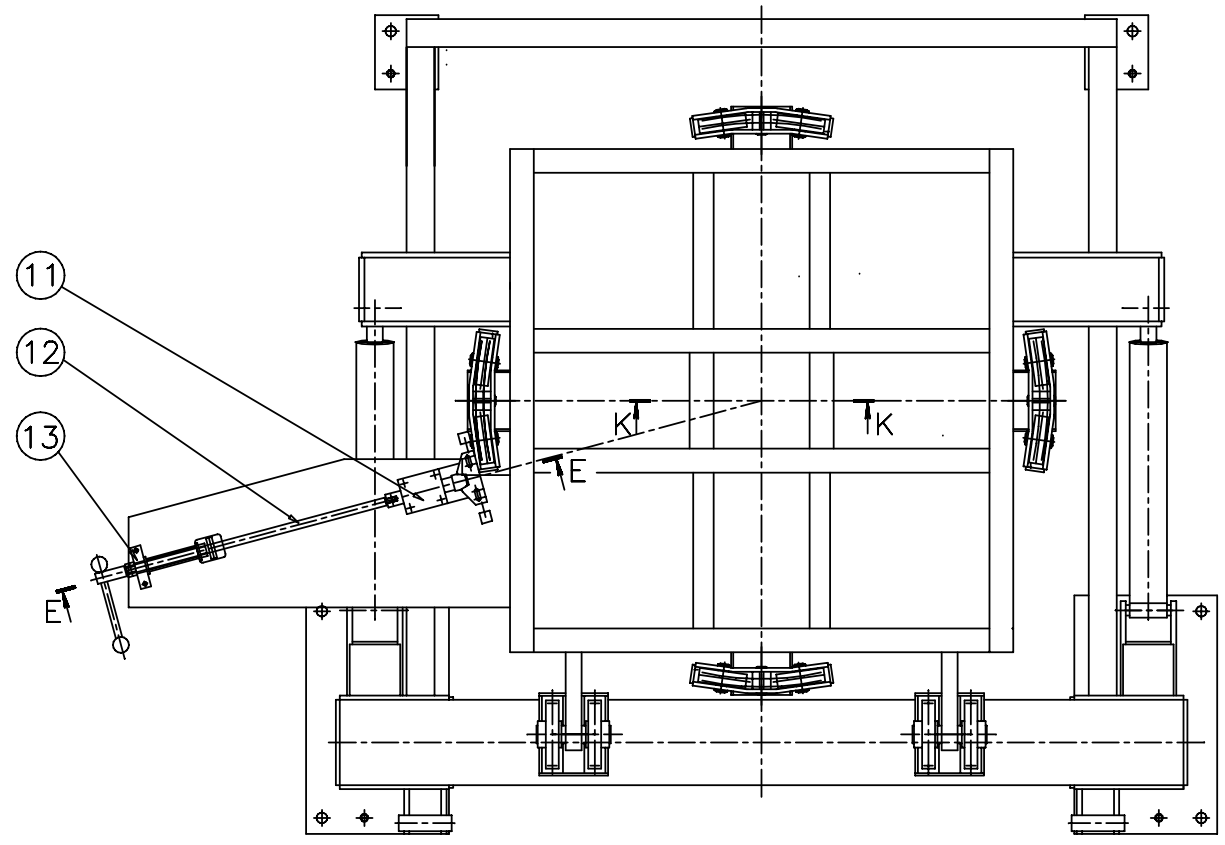

SECTION D-D

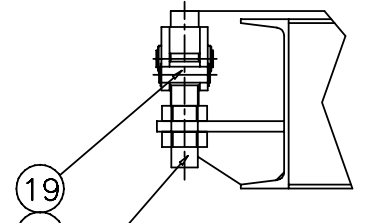

SECTION H-H
scale 1:4

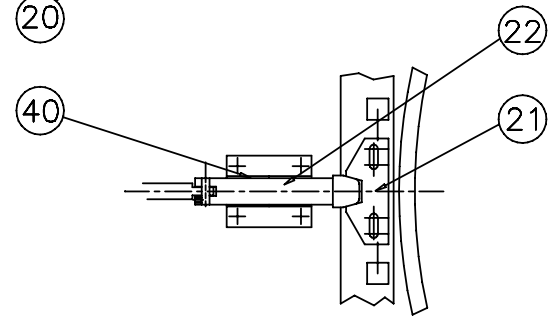

SECTION J-J
scale 1:4

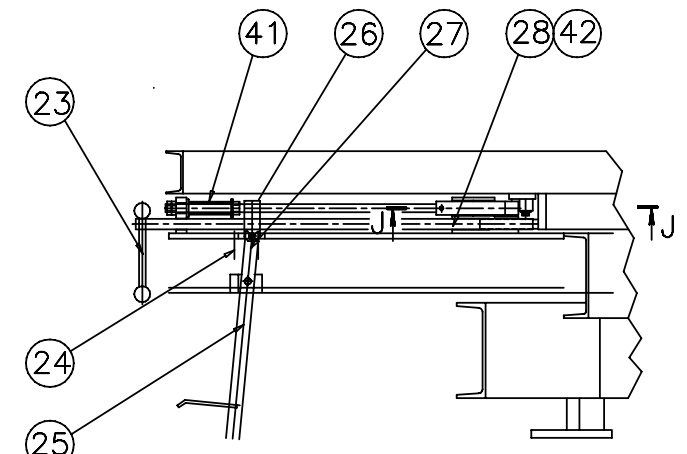

SECTION E-E

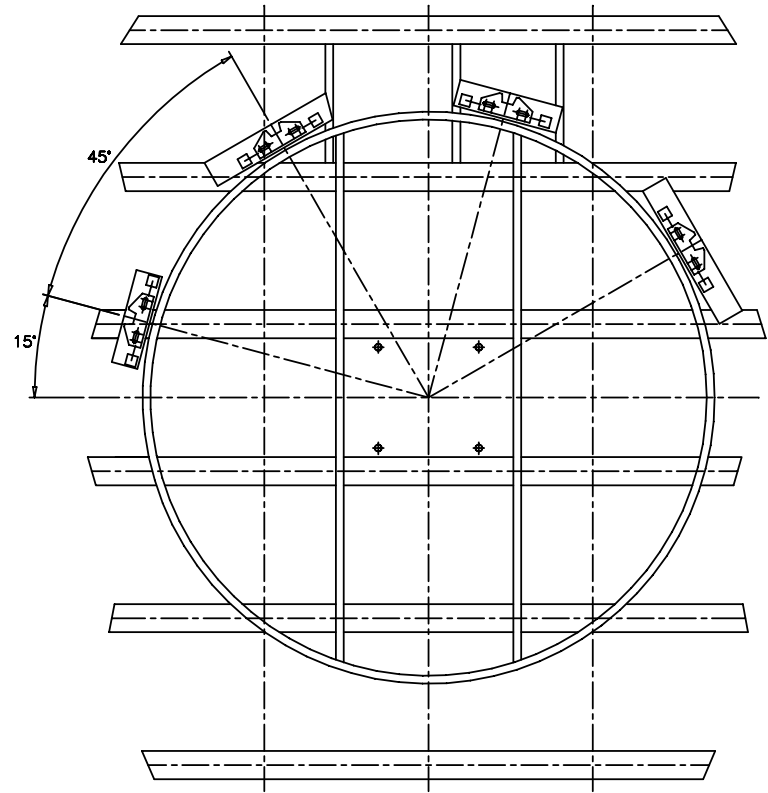

SECTION A-A

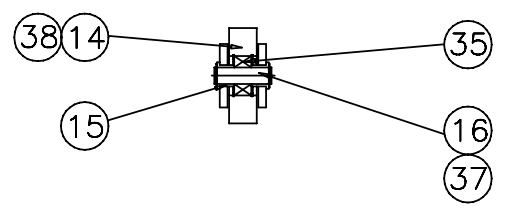

SECTION G-G
scale 1:4

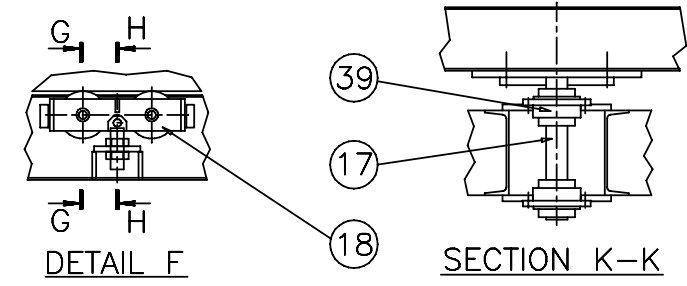

DETAIL F

SECTION K-K

ITEM	REQ	DRAWING	DESCRIPTION	PART NO.
42	1	Andrews	Bearing B-5	
41	1	Assoc. Spring	Spring C1225-148-5000	
40	2	Bunting	Bushing AA1407-6	
39	2	Dodge	Piloted flange bearing O23130	
38	16	---	Retaining ring N5000-185	
37	16	---	Retaining ring 5100-78	
36	8	Truarc	Retaining ring 5100-75	
35	8	---	Bearing W204PP	
34	4	Fafnir	Pillow block RAK 1 11/16 bore	
33	2	Prince Hyd. Cyl	Cyl 214-55B/#3x20stroke/	
32	8		Jam nut 1.5-12	
28	1	B-4481-3A	Screw	
27	1	A-4494-10A	Pin	
26	1	A-4494-9A	Pin	
25	1	B-4481-8A	Pedal	
24	1	A-4494-2A	Yoke	
23	1	A-4494-3	Handle bar	

ITEM		DESCRIPTION		PART NO.	
 SAWING SYSTEMS INC. P.O. Box 3754 Knoxville TN 37927-3754 (865) 525-0600 (800) 489-0601 Telefax (865) 525-2320					
TITLING TABLE ASSEMBLY DWG					
DRAWN BY-		M.Finkel		DATE- May 12 98	
CHECKED BY-				SCALE- 1:8	
MATERIAL-		REQ'D-		DRAWING NO.	
LTR.		REVISION		DATE FOR-	
				E-4021-8D	